

**Low-Noise Boost
DC-DC Converter**

Description

The FP6790 is a step-up current mode PWM DC/DC converter with an internal 1.6A, 0.25Ω N-channel MOSFET. Pin selectable fixed switching frequency (1.2MHz or 640kHz) and external compensation pin provide the user flexibility in setting the loop dynamic, allowing the use of tiny, low profile inductors and low value, low ESR ceramic output capacitors.

The FP6790 provides soft-start feature which is programmable with an external capacitor. In shutdown mode, current consumption is reduced to only 0.1μA. The FP6790 converts the input voltage ranged from 2.6V to 5.5V into an output voltage up to 12V.

FP6790 is available in the space-saving MSOP-8 package.

Features

- Operating Voltage from 2.6V to 5.5V
- Output Voltage from Input Voltage to 12V
- 90% Efficiency
- 1.6A, 0.25Ω Internal Power MOSFET
- Pin Selectable Switching Frequency (1.2MHz or 640kHz)
- Programmed Soft Start
- External Compensation Network
- 0.1μA Shutdown Current
- MSOP-8 Package
- RoHS Compliant

Applications

- LCD Display
- Portable Application
- Hand-Held Device
- Digital Camera

Pin Assignments

MS Package (MSOP-8)

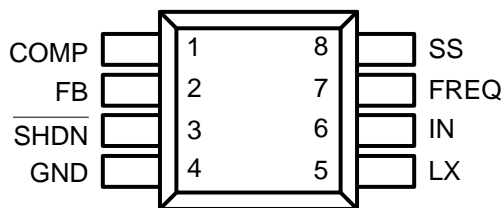
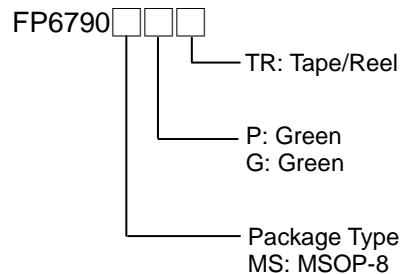

Figure 1. Pin Assignment of FP6790

Ordering Information



Typical Application Circuit

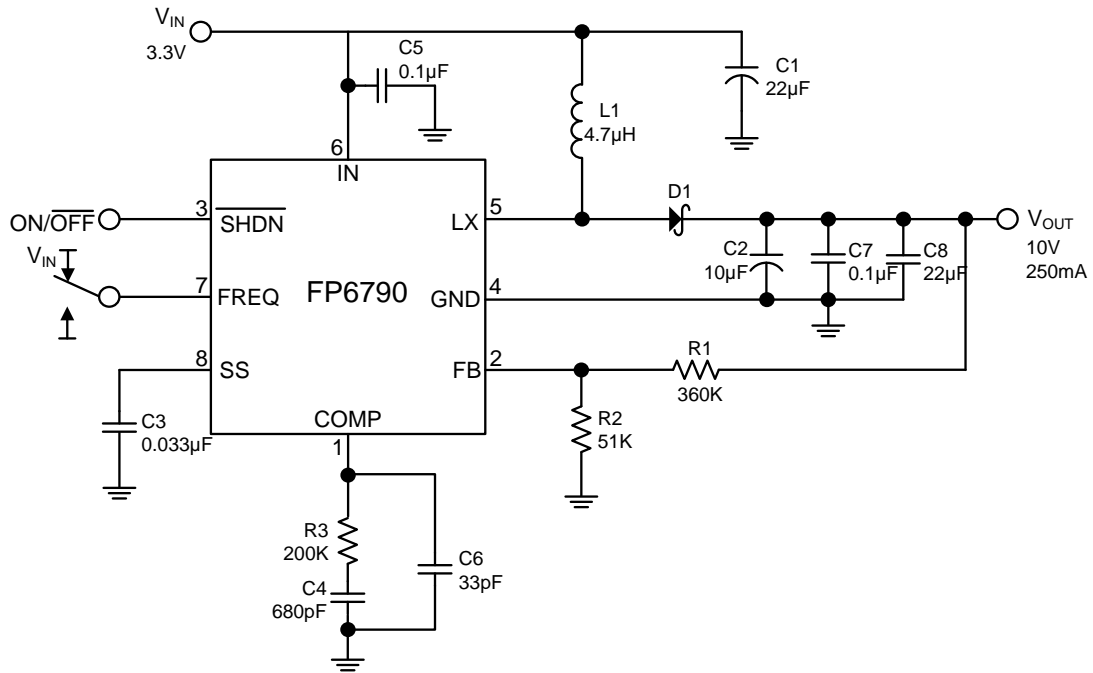

Figure 2. Typical Application Circuit of FP6790

V _{IN} (V)	V _{OUT} (V)	f _{osc} (kHz)	L (µH)	C _{OUT} (µF)	R3 (kΩ)	C4 (pF)	C6 (pF)	I _{OUT(MAX)} (mA)
3.3	10	640	10 (TDK SLF7045)	33 (Ceramic)	120	1000	47	250
3.3	10	1200	4.7 (TDK SLF7045)	33 (Ceramic)	200	680	33	250

Functional Pin Description

Pin Name	Pin Function
COMP	Compensation Pin for Error Amplifier. Connect a series RC from COMP to ground.
FB	Feedback Pin. The typical reference voltage is 1.24V. Set $V_{OUT} = 1.24V (1 + R1/R2)$. See Figure 2.
SHDN	Enable Pin. Connect \overline{SHDN} low to turn off FP6790.
GND	Ground.
LX	Switching Pin.
IN	Power Input Pin.
FREQ	Frequency Select Pin. When FREQ connects to ground, the frequency is 640kHz. When FREQ connects to V _{IN} , the frequency is 1.2MHz.
SS	Soft-Start Control Pin. Connect a capacitor (C3) to this pin. The pin will source 4µA constant current to charge the capacitor. Leave this pin floating to skip soft-start function.

Block Diagram

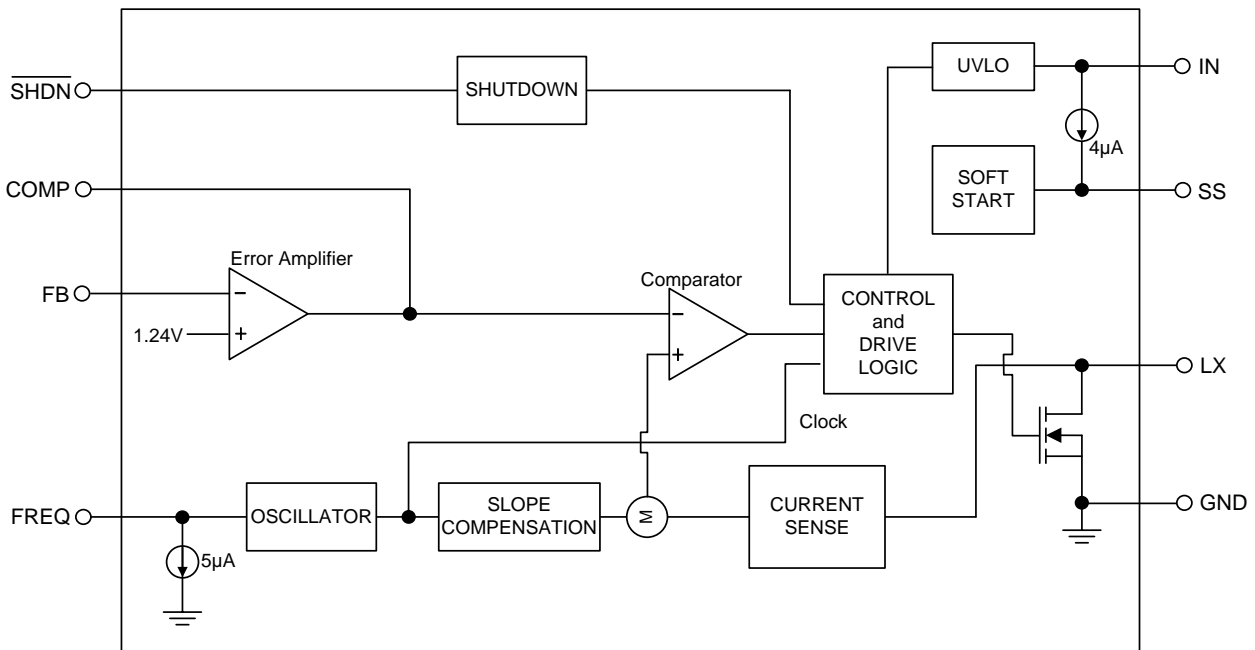

Figure 3. Block Diagram of FP6790

Absolute Maximum Ratings

- VIN to GND ----- -0.3V to +6V
- LX to GND ----- -0.3V to +14V
- $\overline{\text{SHDN}}$, FB, SS, FREQ, COMP to GND ----- -0.3V to +6V
- Power Dissipation @ TA=25°C, MSOP-8 (PD) ----- 630mW
- Package Thermal Resistance, MSOP-8 (θJA) ----- 160°C/W
- Junction Temperature ----- +150°C
- Storage Temperature Range ----- -65°C to +150°C
- Lead Temperature (Soldering, 10sec.) ----- 260°C

Note 1 : Stresses beyond those listed under "Absolute Maximum Ratings" may cause permanent damage to the device.

Recommended Operating Conditions

- Supply Voltage, VIN ----- 3.3V±10%, 5V±10%
- Max. Output Voltage ----- 12V
- Operation Temperature Range ----- -40°C to +85°C

Electrical Characteristics

($V_{IN}=3V$, $\overline{SHDN}=3V$, $FREQ=GND$, $T_A=25^\circ C$, unless otherwise specified)

Parameter	Symbol	Test Conditions	Min	Typ	Max	Units
INPUT						
Operation Voltage Range	V_{IN}		2.6		5.5	V
V_{IN} Under Voltage Lockout	UVLO	V_{IN} rising, typical hysteresis is 100mV	2.25	2.38	2.52	V
Quiescent Current	I_{IN}	$V_{FB}=1.3V$, not switching		160	350	μA
		$V_{FB}=1V$, switching		0.8	5	mA
Shutdown Current	I_{SD}	$\overline{SHDN}=0V$		0.1	10	μA
ERROR AMPLIFIER						
Feedback Voltage	V_{FB}		1.222	1.24	1.258	V
FB Input Bias Current	I_{FB}	$V_{FB}=1.24V$			40	nA
Feedback Line Regulation		$2.6V < V_{IN} < 5.5V$		0.08	0.3	%/V
Transconductance (Note2)	gm	$\Delta I = 5\mu A$	70	170	240	μS
Voltage Gain (Note2)	A_V			700		V/V
OSCILLATOR						
Frequency	F_{OSC}	$FREQ=GND$	540	640	740	kHz
		$FREQ=V_{IN}$	1000	1200	1500	kHz
Maximum Duty Cycle	T_{DUTY}	$FREQ=GND$	79	85	92	%
		$FREQ=V_{IN}$		84		%
N-CHANNEL SWITCH						
Current Limit (Note2)	I_{LIM}		1.2	1.6	2.3	A
On-Resistance (Note2)	R_{ON}	$I_{LX} = 200mA$		0.25	0.5	Ω
Leakage Current	I_{LXOFF}	$V_{LX}=12V$		0.01	20	μA
SOFT-START						
Reset Switching Resistance					100	Ω
Charge Current	I_{SS}	$V_{SS}=1.2V$	1.5	4	7	μA
CONTROL INPUTS						
Input High Level	V_{IH}	\overline{SHDN} , FREQ	$0.7 \cdot V_I$			V
Input Low Level	V_{IL}	\overline{SHDN} , FREQ			$0.3 \cdot V_I$	V
Hysteresis		\overline{SHDN} , FREQ		$0.1 \cdot V_I$		V
Frequency Pull-down Current	I_{FREQ}		1.8	5	9	μA
\overline{SHDN} Input Current	$I_{\overline{SHDN}}$			0.001	1	μA
PROTECTION						
Thermal Shutdown Temperature (Note2)	T_{SD}			140		$^\circ C$
	ΔT_{SD}	Hysteresis		25		$^\circ C$

Note 2 : Guarantee by design

Typical Performance Curves

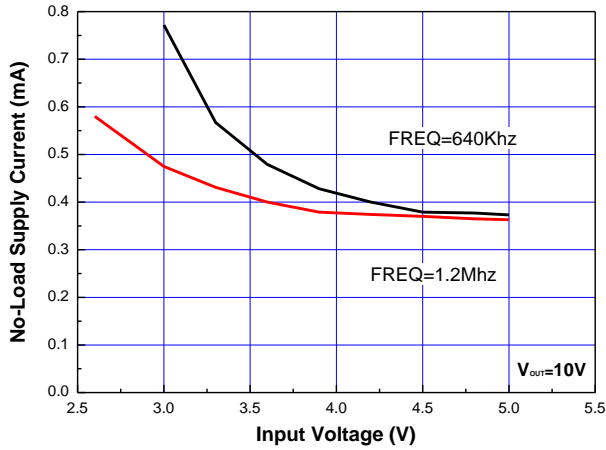

Figure 4. No-Load Supply Current vs. Input Voltage

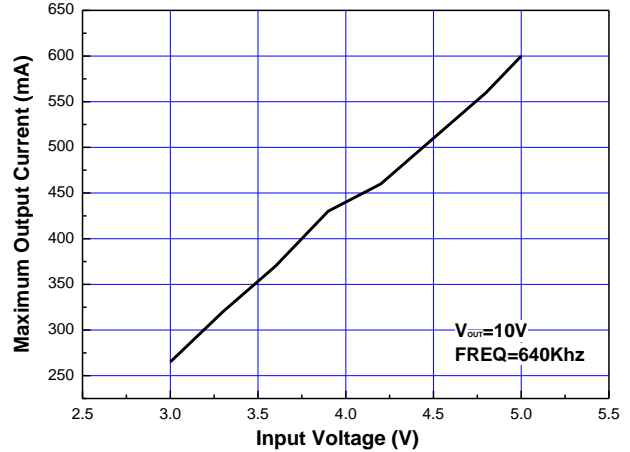

Figure 5. Maximum Output Current vs. Input Voltage

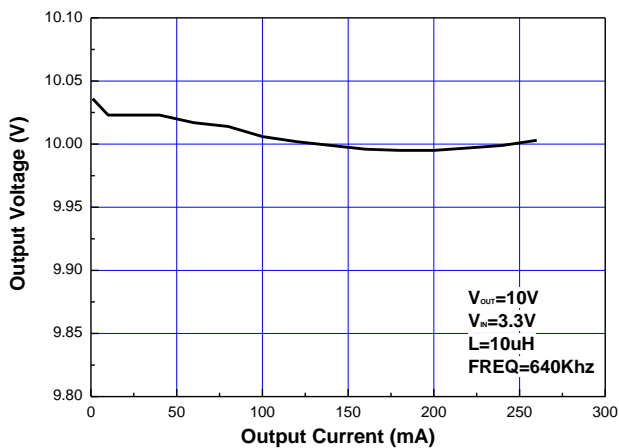

Figure 6. Output Voltage vs. Output Current

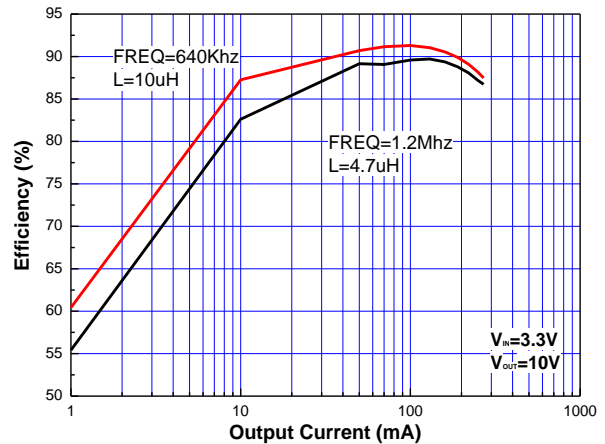

Figure 7. Efficiency vs. Output Current

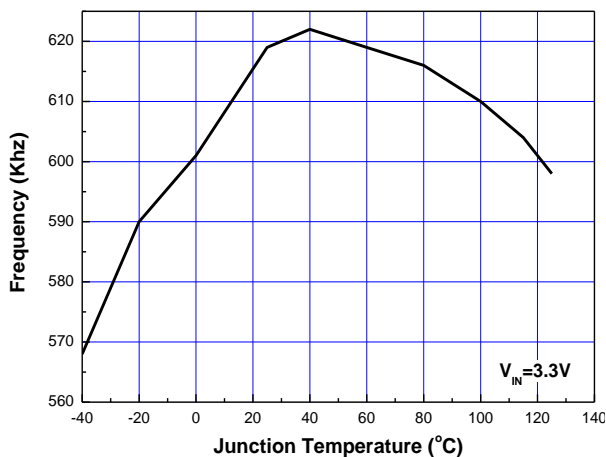

Figure 8. Frequency vs. Junction Temperature

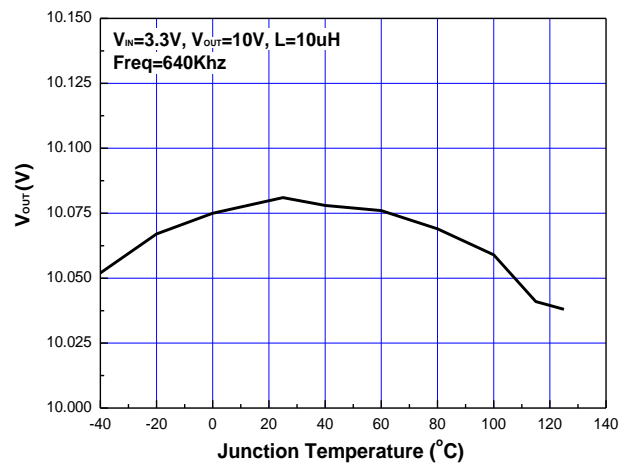
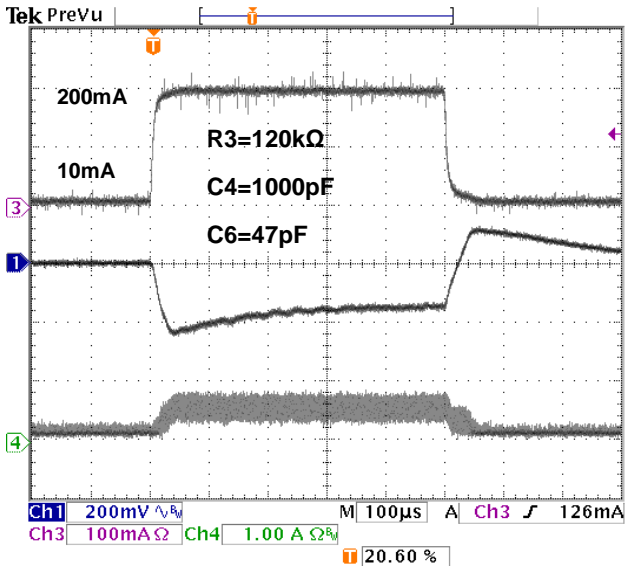

Figure 9. Output Voltage vs. Junction Temperature

Typical Performance Curves (Continued)



CH1: Output Voltage, AC-Coupled
 CH3: Load Current
 CH4: Inductor Current
 $V_{IN}=3.3V$, $V_{OUT}=10V$, $FREQ=640kHz$, $C_{OUT}=33\mu F+0.1\mu F$

Figure 10. Load transient Response

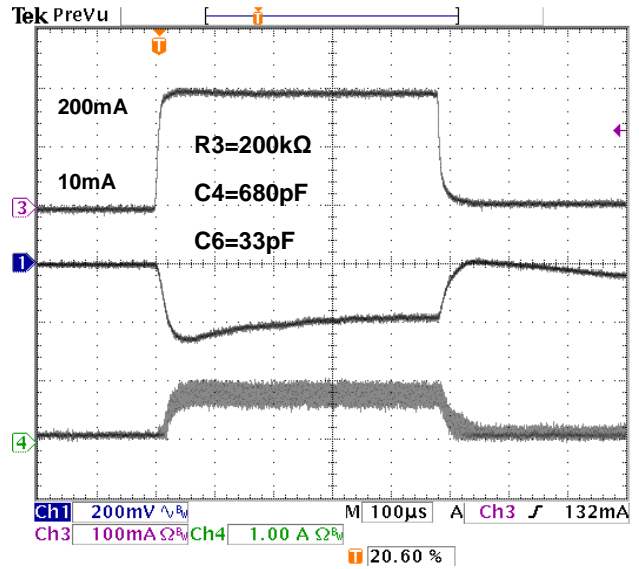

CH1: Output Voltage, AC-Coupled
 CH3: Load Current
 CH4: Inductor Current
 $V_{IN}=3.3V$, $V_{OUT}=10V$, $FREQ=1.2MHz$, $C_{OUT}=33\mu F+0.1\mu F$

Figure 11. Load transient Response

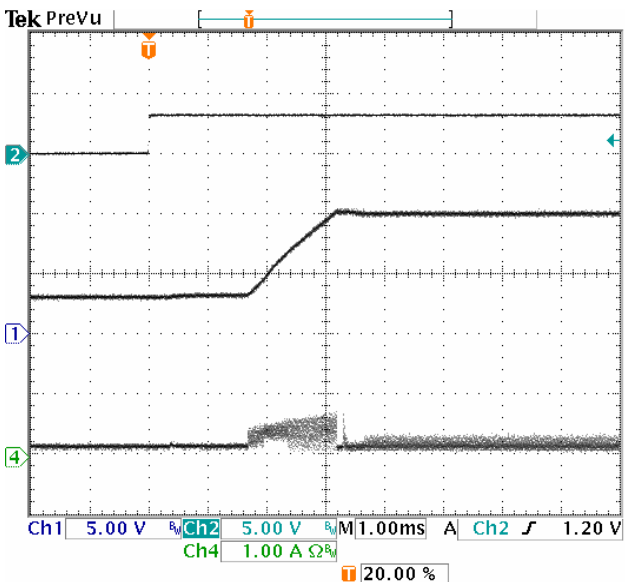

CH1: Output Voltage
 CH2: SHDN
 CH4: Inductor Current
 $V_{IN}=3.3V$, $V_{OUT}=10V$, $I_{OUT}=10mA$, $L=10\mu H$, $C3=33nF$,
 $FREQ=640kHz$, $C_{OUT}=33\mu F$

Figure 12. Start-up Waveform with Soft-start

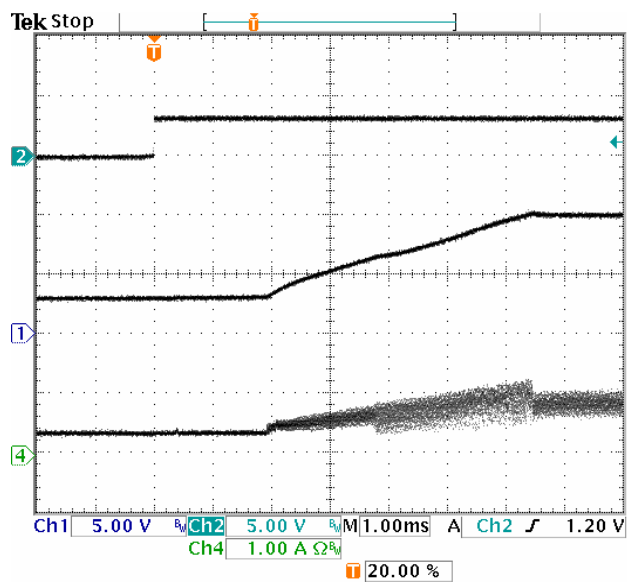

CH1: Output Voltage
 CH2: SHDN
 CH4: Inductor Current
 $V_{IN}=3.3V$, $V_{OUT}=10V$, $I_{OUT}=200mA$, $L=10\mu H$, $C3=33nF$,
 $FREQ=640kHz$, $C_{OUT}=33\mu F$

Figure 13. Start-up Waveform with Soft-start

Typical Performance Curves (Continued)

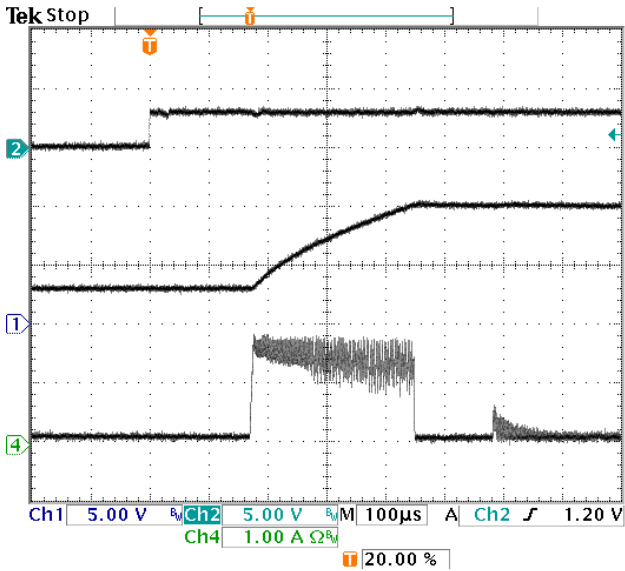

CH1: Output Voltage
CH2: SHDN
CH4: Inductor Current
 $V_{IN}=3.3V$, $V_{OUT}=10V$, $I_{OUT}=10mA$, $L=10\mu H$,
 without soft start, $FREQ=640kHz$, $C_{OUT}=33\mu F$

Figure 14. Start-up Waveform without Soft-start

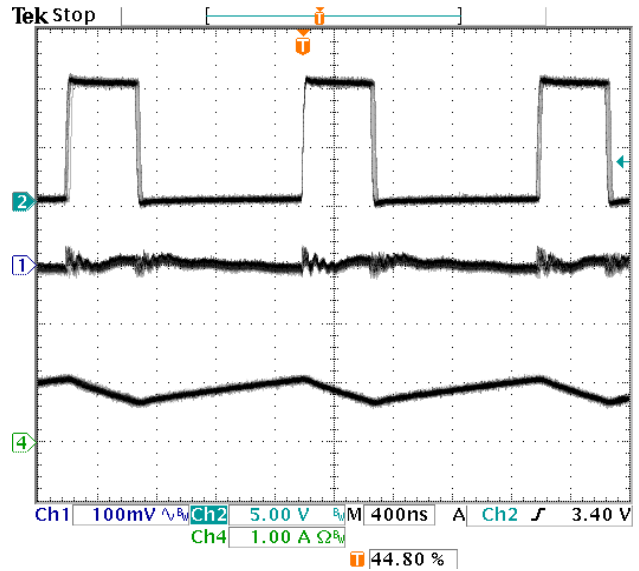

CH1: Output Voltage, AC-Coupled
CH2: LX Switching Waveform
CH4: Inductor Current
 $V_{IN}=3.3V$, $V_{OUT}=10V$, $I_{OUT}=200mA$, $L=10\mu H$,
 $FREQ=640kHz$, $C_{OUT}=33\mu F+0.1\mu F$

Figure 15. Switching Waveform

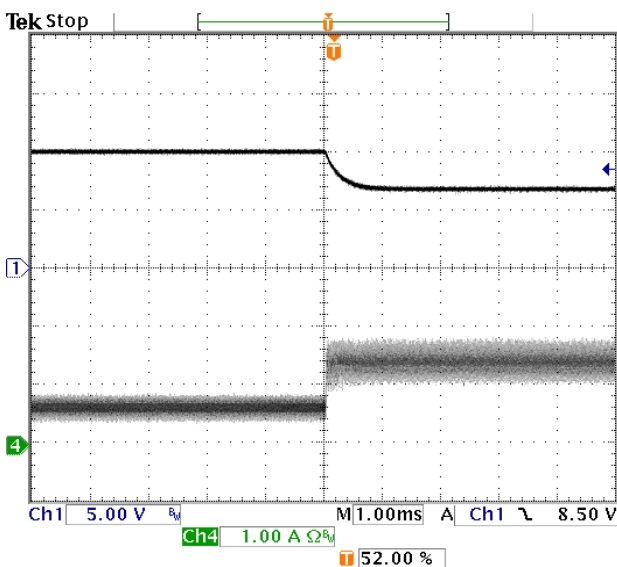

CH1: Output Voltage
CH4: Inductor Current
 $V_{IN}=3.3V$, $V_{OUT}=10V$, $I_{OUT}=500mA$, $FREQ=640kHz$,
 $L=10\mu H$

Figure 16. OCP Waveform

Outline Information

MSOP-8 Package (Unit: mm)

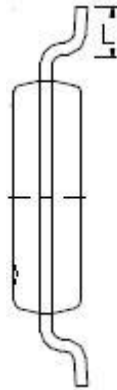

SYMBOLS UNIT	DIMENSION IN MILLIMETER	
	MIN	MAX
A	0.75	1.10
A1	0.00	0.15
A2	0.75	0.95
B	0.25	0.35
D	2.90	3.10
E	4.80	5.00
E1	2.90	3.10
e	0.60	0.70
L	0.40	0.80

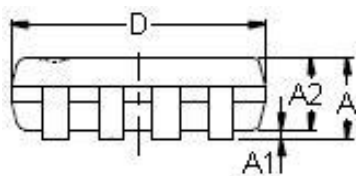

Carrier dimensions

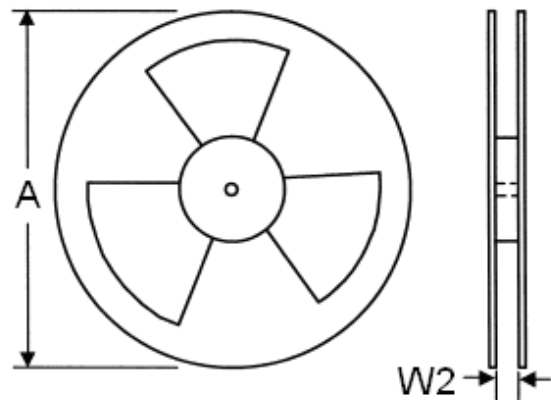
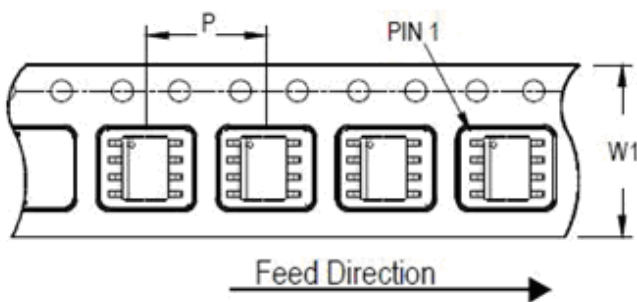

Tape Size (W1) mm	Pocket Pitch (P) mm	Reel Size (A)		Reel Width (W2) mm	Empty Cavity Length mm	Units per Reel
		in	mm			
12	8	13	330	12.4	400~1000	3,000

Life Support Policy

Fitipower's products are not authorized for use as critical components in life support devices or other medical systems.