

# 800mA Low Dropout Positive Regulator

## FEATURES

- Dropout Voltage 1.2V at 800mA Output Current.
- Fast Transient Response.
- Line Regulation typically at 0.015%.
- Load Regulation typically at 0.1%.
- Current Limiting and Thermal Protection.
- Adjustable Output Voltage or Fixed 1.8V, 2.5V, 2.85V, 3.3V, 5V.
- Standard 3-Pin Power Packages.

## APPLICATIONS

- SCSI-2 Active Terminator.
- Post Regulator for Switching Supply.
- Battery Chargers.
- Constant-Current Regulators.
- PC Add-On Card.

## TYPICAL APPLICATION CIRCUIT



**Adjustable Voltage Regulator**

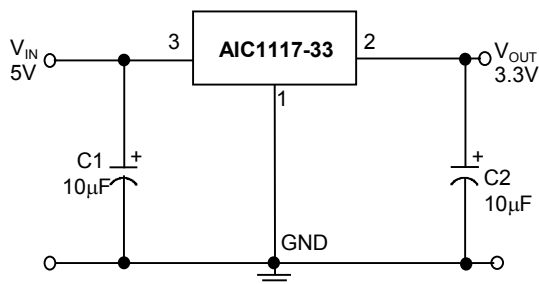

**Fixed Voltage Regulator**

## DESCRIPTION

The AIC1117 is a low dropout three terminal regulator with 800mA output current capability. The output voltage is adjustable with the use of a resistor divider. For fixed output voltage versions, the output voltage is internally set at 1.8V, 2.5V, 2.85V, 3.3V, or 5V. Dropout voltage is guaranteed to be at a maximum of 1.3 V with the maximum output current. Its low dropout voltage and fast transient response make it ideal for low voltage microprocessor applications. Current limiting and thermal protection provide protection against any overload condition that would create excessive junction temperatures.

$$V_{REF} = V_{OUT} - V_{ADJ} = 1.25V \text{ (typ.)}$$

$$V_{OUT} = V_{REF} \times (1 + RF2/RF1) + I_{ADJ} \times RF2$$

$$I_{ADJ} = 55\mu A \text{ (typ.)}$$

- (1) C1 needed if device is far away from filter capacitors.
- (2) C2 required for stability.

## ORDERING INFORMATION

AIC1117-XXCXXX

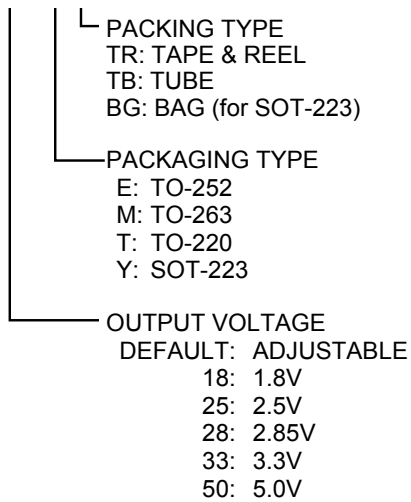

Example: AIC1117-25CETR  
 → 2.5V version in TO-252 Package  
 & Taping & Reel Packing Type

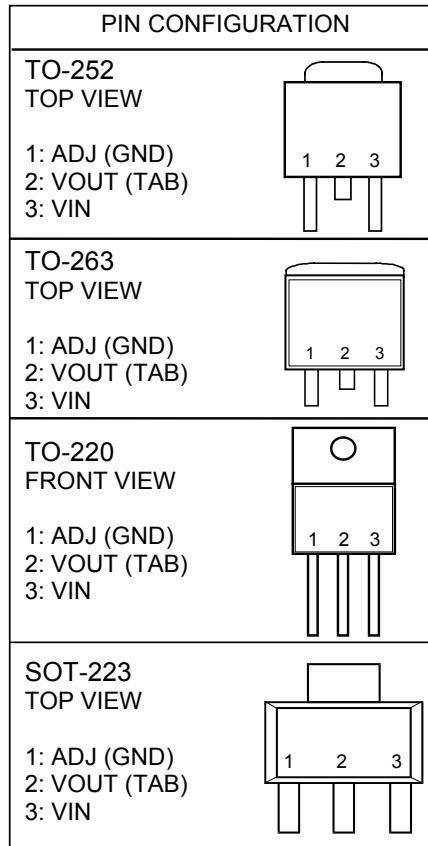

### ● SOT-223 Marking

Part No.	Marking
AIC1117CY	AK17
AIC1117-18CY	AK18
AIC1117-25CY	AK25
AIC1117-28CY	AK28
AIC1117-33CY	AK33
AIC1117-50CY	AK50

**■ ABSOLUTE MAXIMUM RATINGS**

VIN pin to ADJ/ GND pin	.....	7V
Operating Junction Temperature Range	.....	0°C ~ 125°C
Storage Temperature Range	.....	- 65°C ~ 150°C
Thermal Resistance (Junction to Case)	TO-220	..... 3°C /W
	TO-252	..... 12.5°C /W
	SOT-223	..... 15°C /W
	TO-263	..... 3°C /W
Thermal Resistance Junction to Ambient (Assume no ambient airflow, no heatsink)	TO-252	..... 100°C/W
	TO-263	..... 60°C /W
	SOT-223	..... 155°C /W
	TO-220	..... 50°C /W
Lead Temperature (Soldering) 10 sec.	.....	260°C

**■ TEST CIRCUIT**

Refer to TYPICAL APPLICATION CIRCUIT.

**ELECTRICAL CHARACTERISTICS** ( $V_{IN}=5V$ ,  $T_J=25^{\circ}C$ ,  $I_O=10mA$ , Unless otherwise specified)

PARAMETER	TEST CONDITIONS	MIN.	TYP.	MAX.	UNIT
Reference Voltage	AIC1117 (ADJ) $T_J=25^{\circ}C$	1.238	1.25	1.262	V
	$0^{\circ}C \leq T_J \leq 125^{\circ}C$	1.225	1.25	1.275	
Output Voltage	AIC1117-18, $V_{IN}=3.3V$	1.78	1.8	1.82	V
	AIC1117-25, $V_{IN}=5V$	2.47	2.5	2.53	
	AIC1117-28, $V_{IN}=5V$	2.82	2.85	2.88	
	AIC1117-33, $V_{IN}=5V$	3.26	3.30	3.33	
	AIC1117-50, $V_{IN}=7V$	4.95	5.00	5.05	
Line Regulation	$2.65 \leq V_{IN} \leq 7V$ , $V_{OUT}=1.25V$ $T_J=25^{\circ}C$		0.015	0.2	%
	$0^{\circ}C \leq T_J \leq 125^{\circ}C$		0.035	0.2	
Load Regulation	$T_J=25^{\circ}C$ $10mA \leq I_O \leq 800mA$		0.1	0.3	%
	$0^{\circ}C \leq T_J \leq 125^{\circ}C$		0.2	0.4	
Dropout Voltage	$\Delta V_{OUT}$ , $\Delta V_{REF}=1\%$ $10mA \leq I_O \leq 800mA$ $0^{\circ}C \leq T_J \leq 125^{\circ}C$		1.2	1.4	V
Current Limit	$0^{\circ}C \leq T_J \leq 125^{\circ}C$	0.85			A
Adjusted Pin Current ( $I_{ADJ}$ )	$2.65 \leq V_{IN} \leq 7V$ $10mA \leq I_O \leq 800mA$ $0^{\circ}C \leq T_J \leq 125^{\circ}C$		55	120	$\mu A$
Adjusted Pin Current Change ( $\Delta I_{ADJ}$ )	$2.65 \leq V_{IN} \leq 7V$ $10mA \leq I_O \leq 800mA$ $0^{\circ}C \leq T_J \leq 125^{\circ}C$		0.2	5	$\mu A$
Temperature Stability	$I_O=0.5A$ $0^{\circ}C \leq T_J \leq 125^{\circ}C$		0.5		%
Minimum Load Current	$0^{\circ}C \leq T_J \leq 125^{\circ}C$		5	10	mA
RMS Output Noise (% of $V_{OUT}$ )	$10Hz \leq f \leq 10KHz$		0.003		%
Ripple Rejection Ratio	120Hz input ripple $C_{OUT}=25\mu F$	60	72		dB

**TYPICAL PERFORMANCE CHARACTERISTICS**

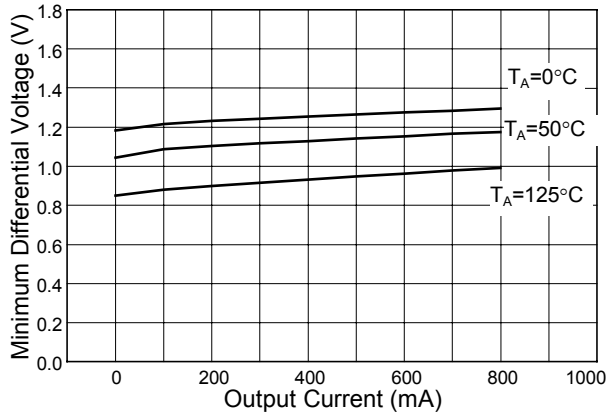

Fig. 1 AIC1117 (ADJ) Dropout Voltage

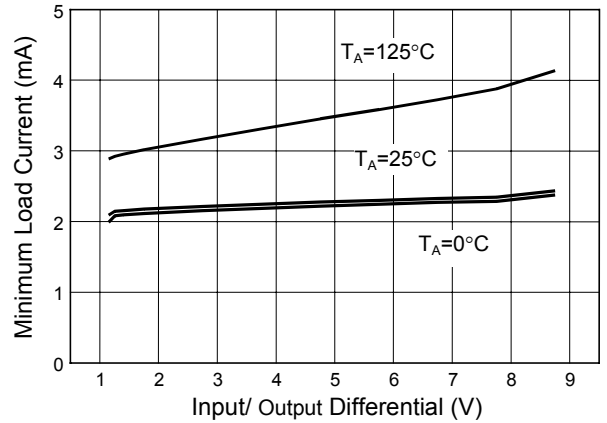

Fig. 2 Minimum Load Current (Adjustable Version)

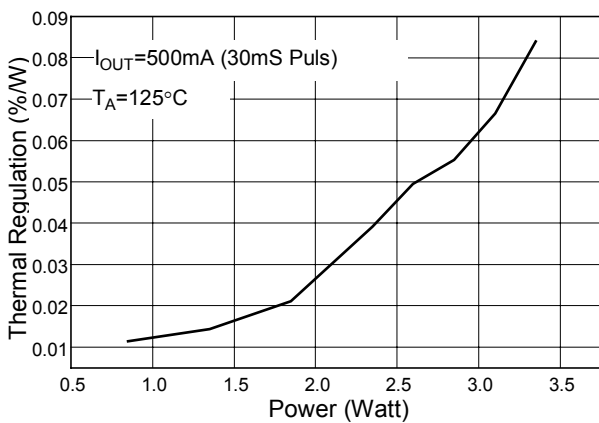

Fig. 3 AIC1117 (ADJ) Power vs. Thermal Regulation

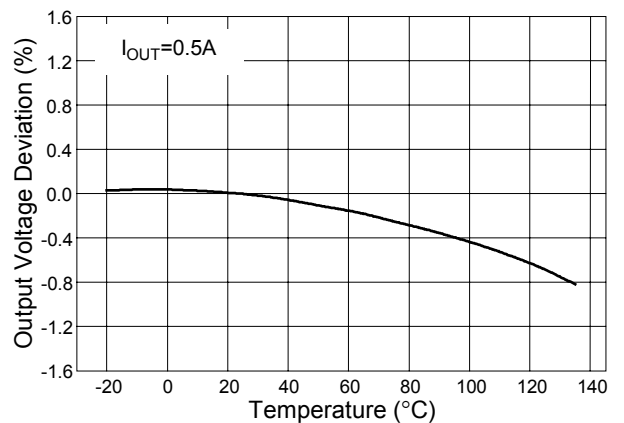

Fig. 4 AIC1117 (ADJ) Temperature Stability

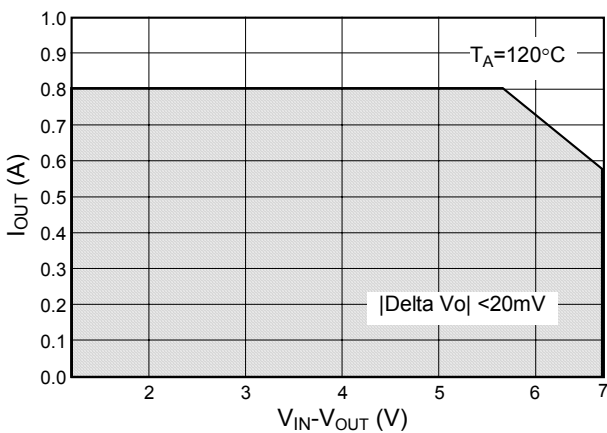

Fig. 5 AIC1117 (ADJ) Maximum Output Current vs.  $V_{IN}-V_{OUT}$

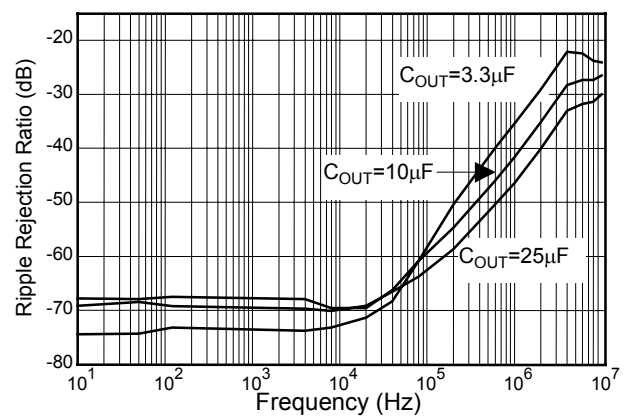
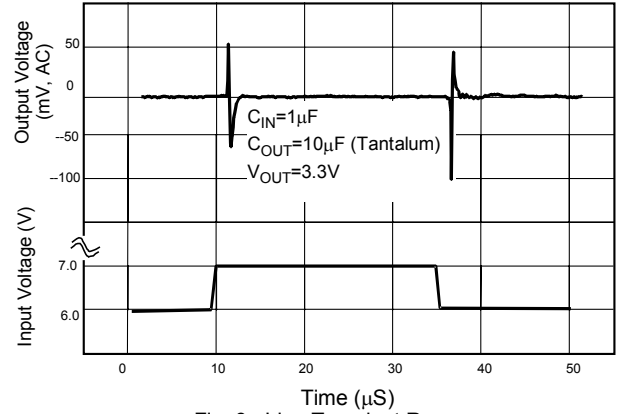
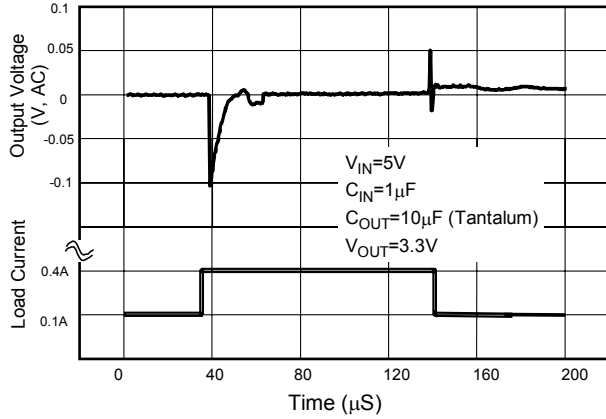
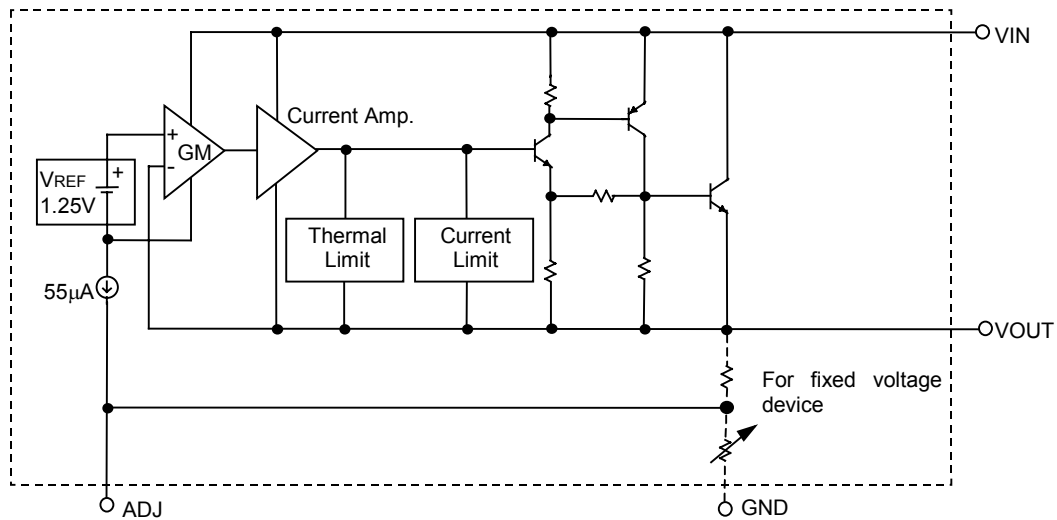

Fig. 6 AIC1117 (ADJ) Ripple Rejection Ratio (dB)

**TYPICAL PERFORMANCE CHARACTERISTICS (Continued)**



**BLOCK DIAGRAM**



**PIN DESCRIPTIONS**

- ADJ PIN - Providing  $V_{REF}=1.25V$  (typ.) for adjustable  $V_{OUT}$ .  $V_{REF}=V_{OUT}-V_{ADJ}$  and  $I_{ADJ}=55\mu A$  (typ.)
- GND PIN - Power ground.
- VOUT PIN - Adjustable output voltage.
- VIN PIN - Power Input.

**PHYSICAL DIMENSIONS**

● TO-220 (unit: mm)

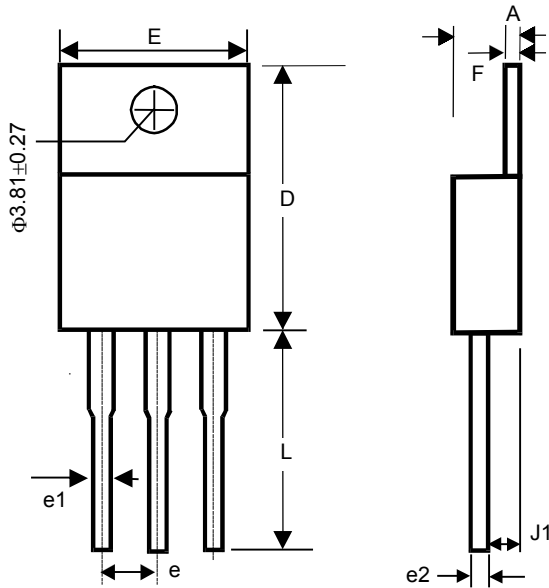

SYMBOL	MIN	MAX
A	3.56	4.82
D	14.23	16.51
E	9.66	10.66
e	2.29	2.79
e1	0.50	1.15
e2	-	1.10
F	0.51	1.39
J1	2.04	2.92
L	12.70	14.73

● TO-252 (unit: mm)

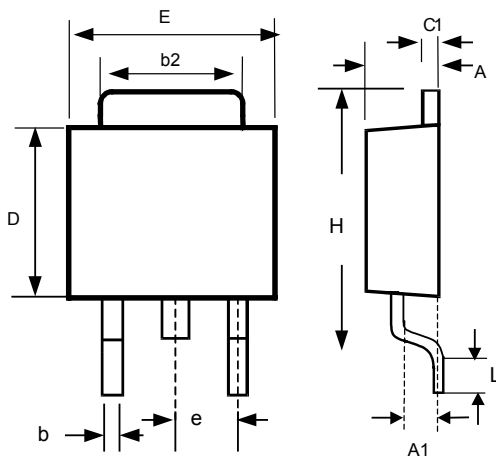

SYMBOL	MIN	MAX
A	2.19	2.38
A1	1.02	1.27
b	0.64	0.88
b2	5.21	5.46
C1	0.46	0.58
D	5.33	5.59
E	6.35	6.73
e	2.28 (TYP.)	
H	9.40	10.42
L	0.51	-

● **SOT-223**

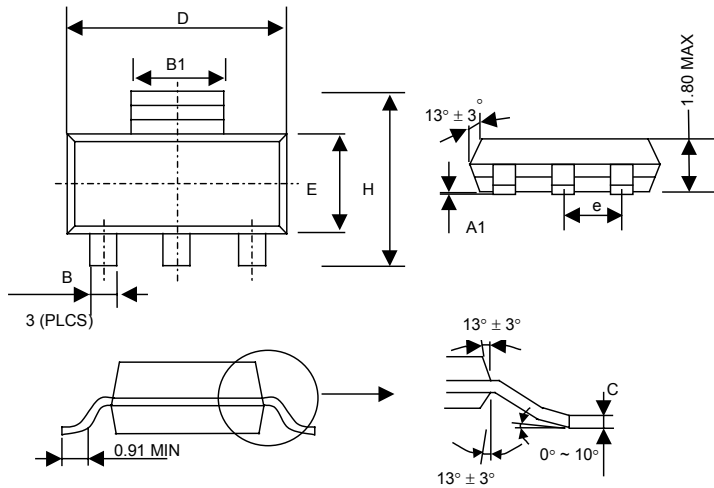

SYMBOL	MIN	MAX
A1	0.02	0.12
B	0.60	0.80
B1	2.90	3.15
C	0.24	0.35
D	6.30	6.80
E	3.30	3.70
e	2.30 (TYP.)	
H	6.70	7.30

● **SOT-223 Marking**

Part No.	Marking
AIC1117CY	AK17
AIC1117-18CY	AK18
AIC1117-25CY	AK25
AIC1117-28CY	AK28
AIC1117-33CY	AK33
AIC1117-50CY	AK50

● **TO-263 (unit: mm)**

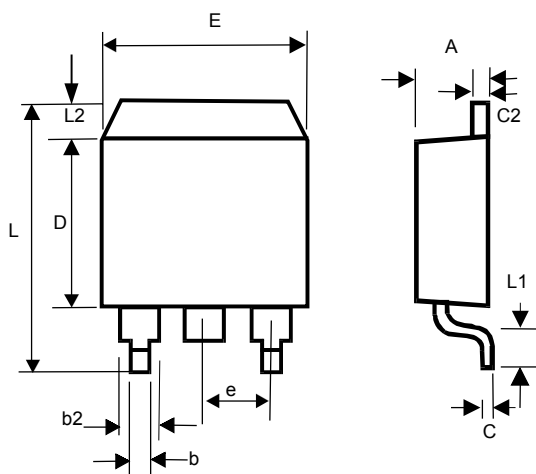

SYMBOL	MIN	MAX
A	4.06	4.83
b	0.50	1.00
b2	1.14	1.40
C	-	0.7
c2	1.14	1.40
D	8.63	9.66
E	9.65	10.29
e	2.54 (TYP.)	
L	14.60	15.88
L1	2.28	2.80
L2	-	1.40